

## IGBT Modules

$V_{CES}$   
 $I_c$

## Applications

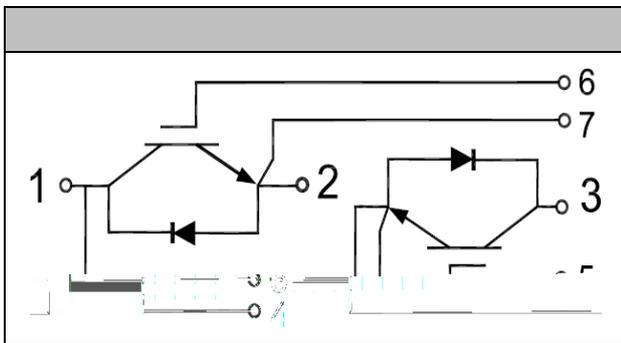

## Features

### ● IGBT

#### Absolute Maximum Ratings

Parameter	Symbol	Conditions	Value	Unit





# MG200HF12LEC2



## ● Diode

### Absolute Maximum Ratings

Parameter	Symbol	Conditions	Value	Unit

### Characteristic values

Parameter	Symbol	Conditions	Value			Unit
			Min.	Typ.	Max.	



# MG200HF12LEC2



● **Module Characteristics**  $T_c=25^\circ\text{C}$  unless otherwise specified

Parameter	Symbol	Conditions	Value			Unit
			Min.	Typ.	Max.	



# MG200HF12LEC2

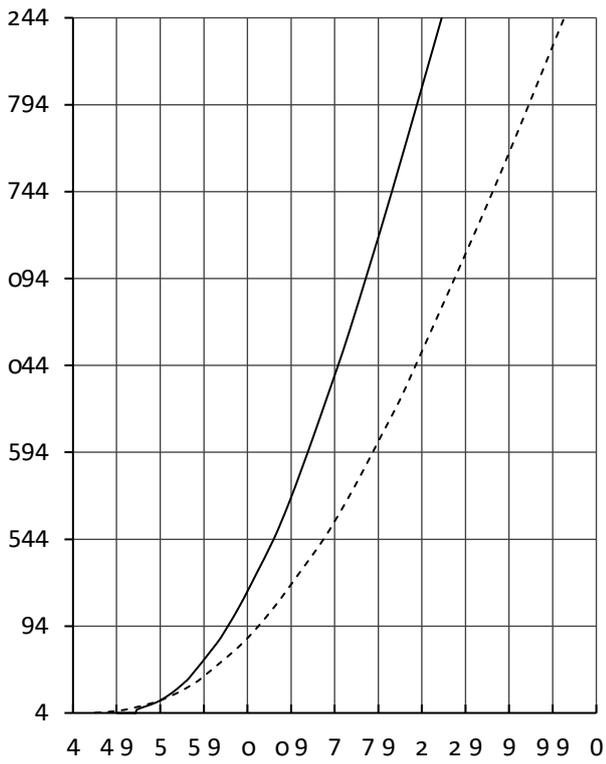



# MG200HF12LEC2

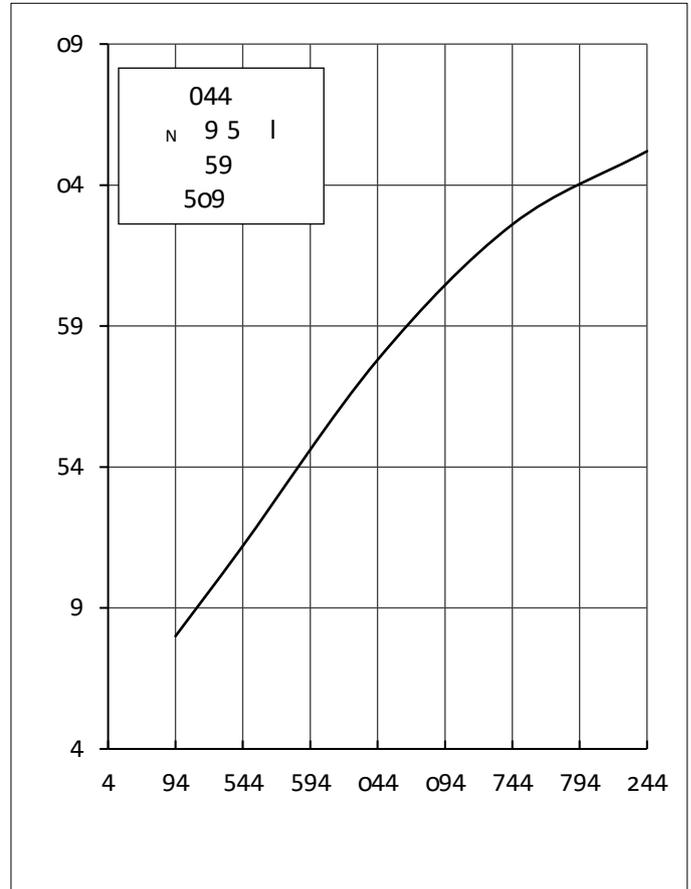
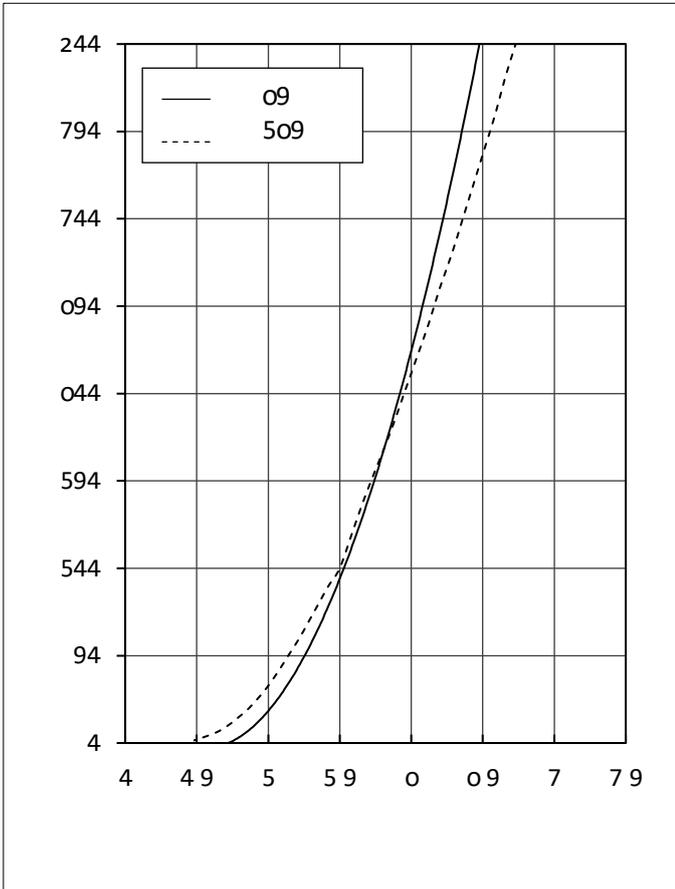
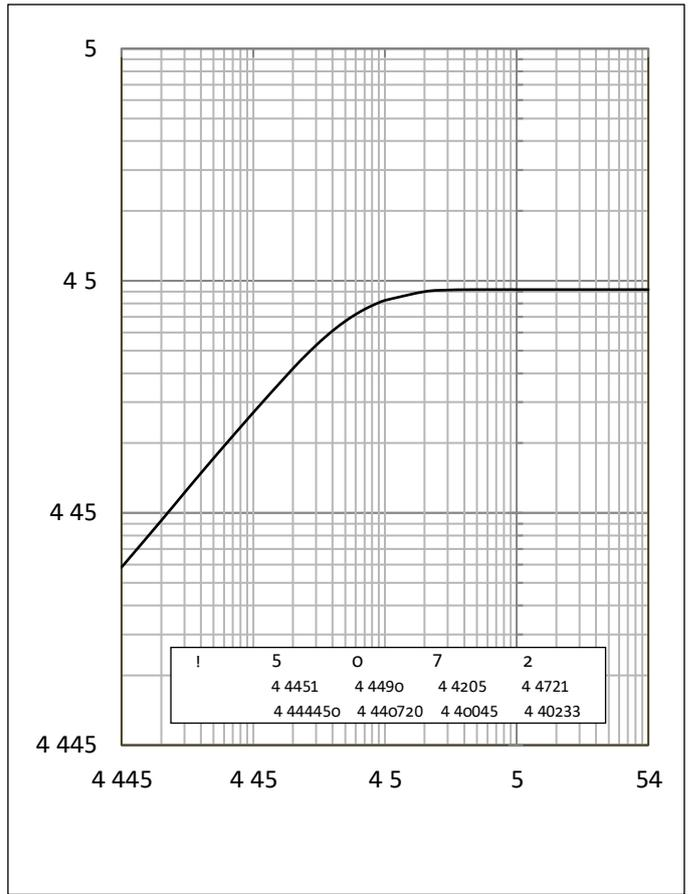
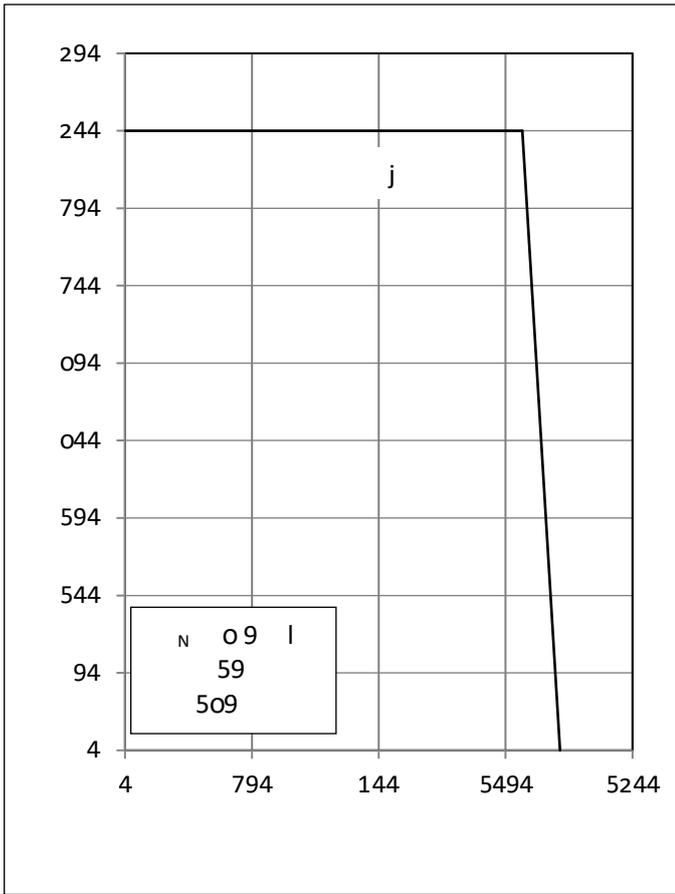



# MG200HF12LEC2

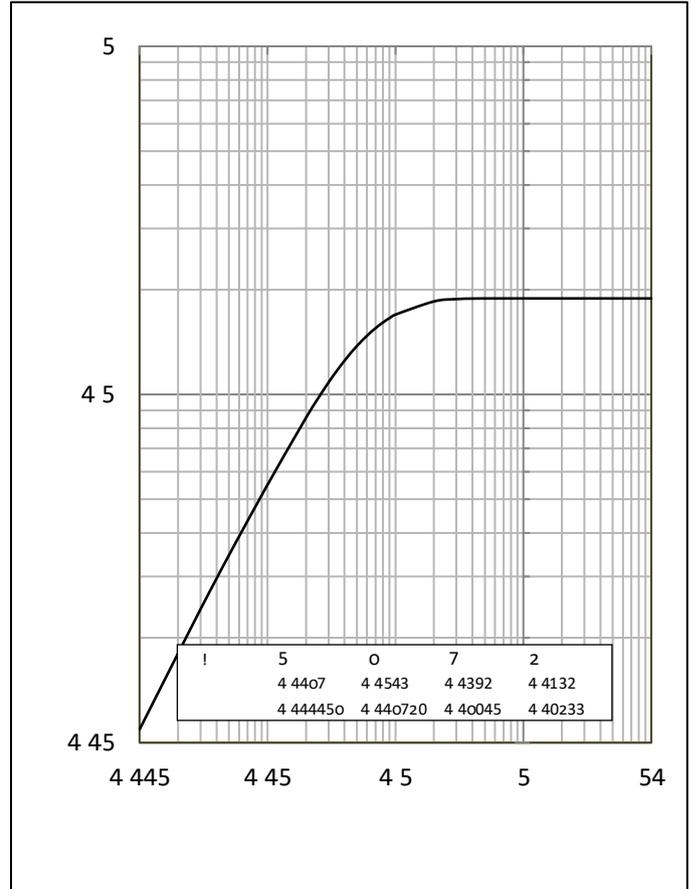
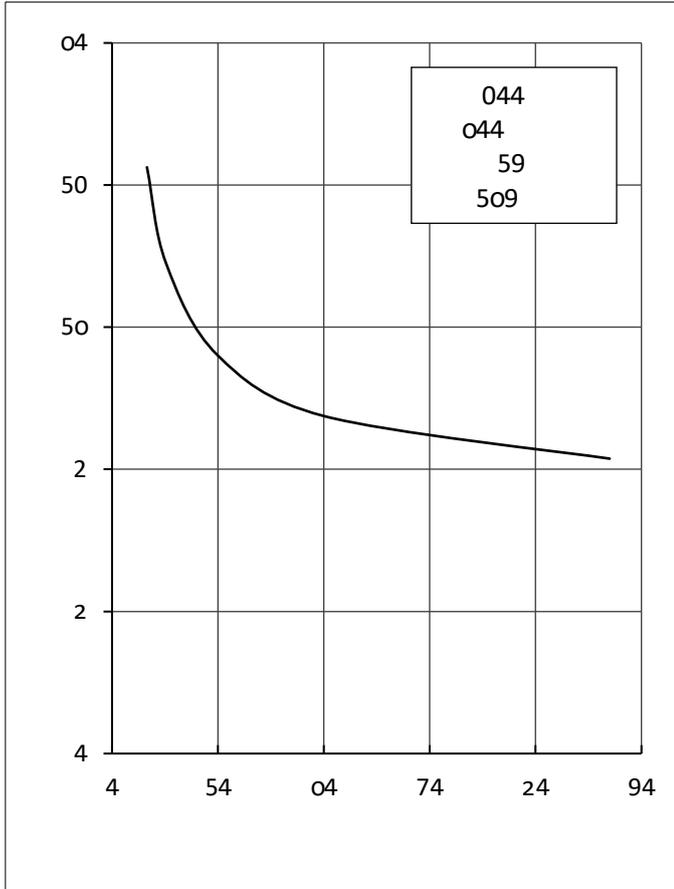



# MG200HF12LEC2



## ● Circuit Diagram

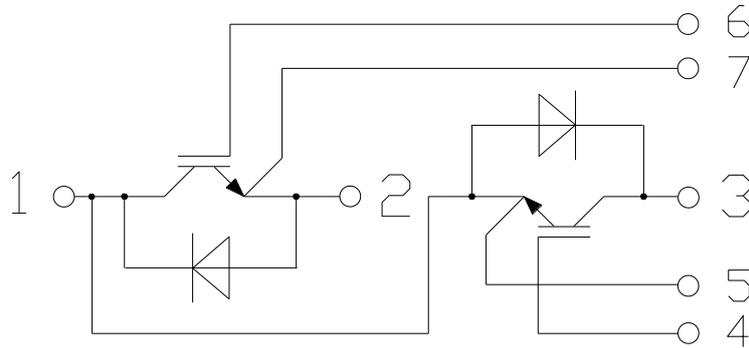

## ● Package Outline Information

Dimensions in Millimeters

