

一级代理商：

深圳市弗瑞鑫电子有限公司

地址：深圳市宝安区西乡大道302号金源商务大厦B座三楼

frxelec

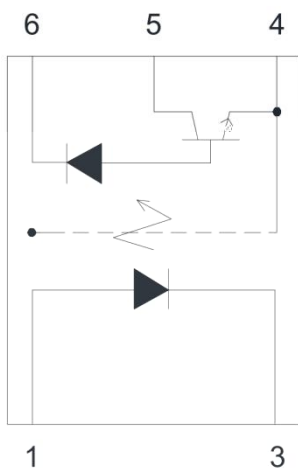
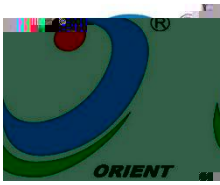

- 1. Anode
- 3. Cathode
- 4. GND
- 5. Vo (Output)
- 6. Vcc

()	

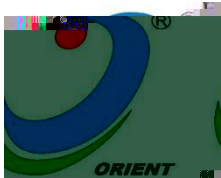

		LW				

XOH 8

o

ANNE PETERHAM

03/13/0



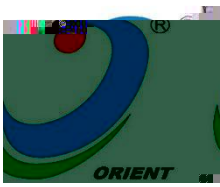

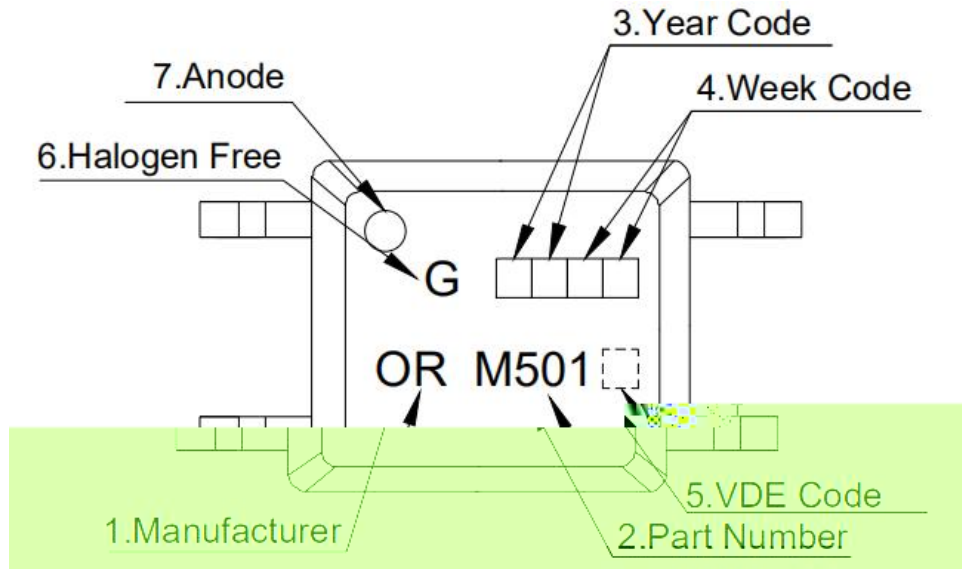
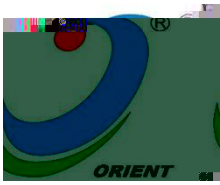

[] [] :

[] [] :

[] [] [] []

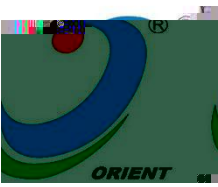

()

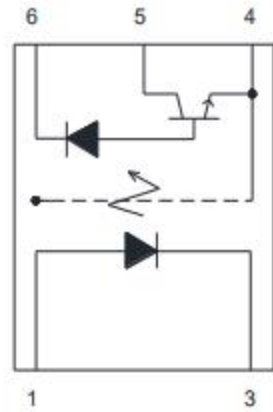
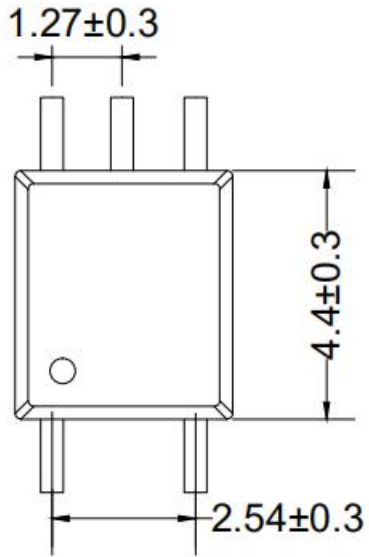

- 1. Anode
- 3. Cathode
- 4. GND
- 5. Vo(Output)
- 6. Vcc

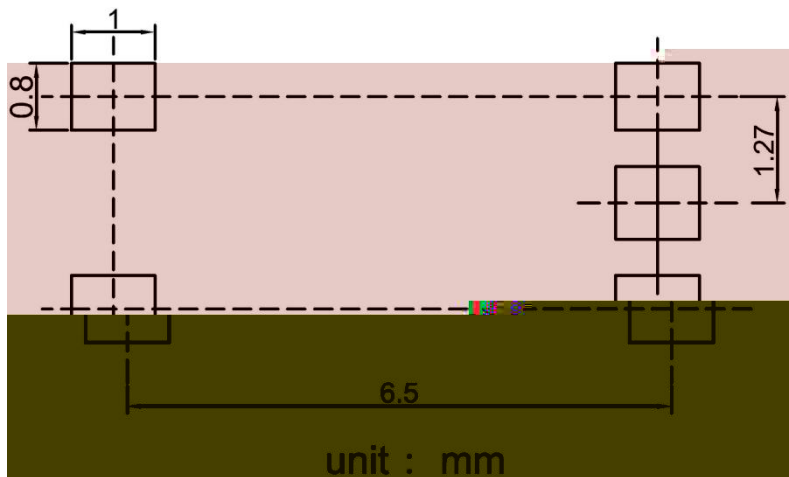
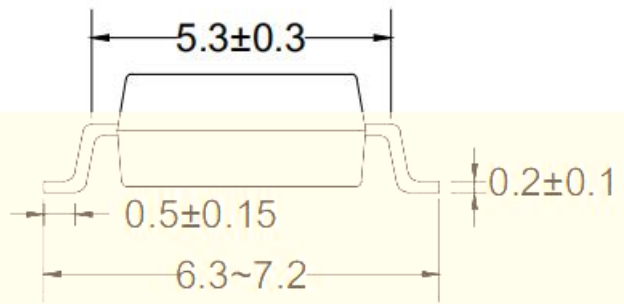
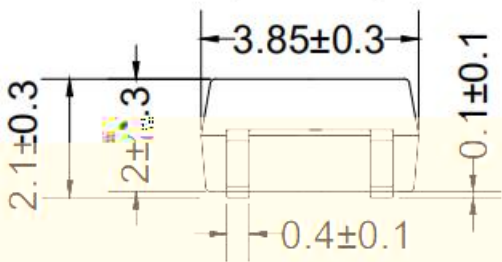

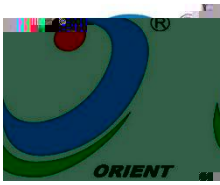

()

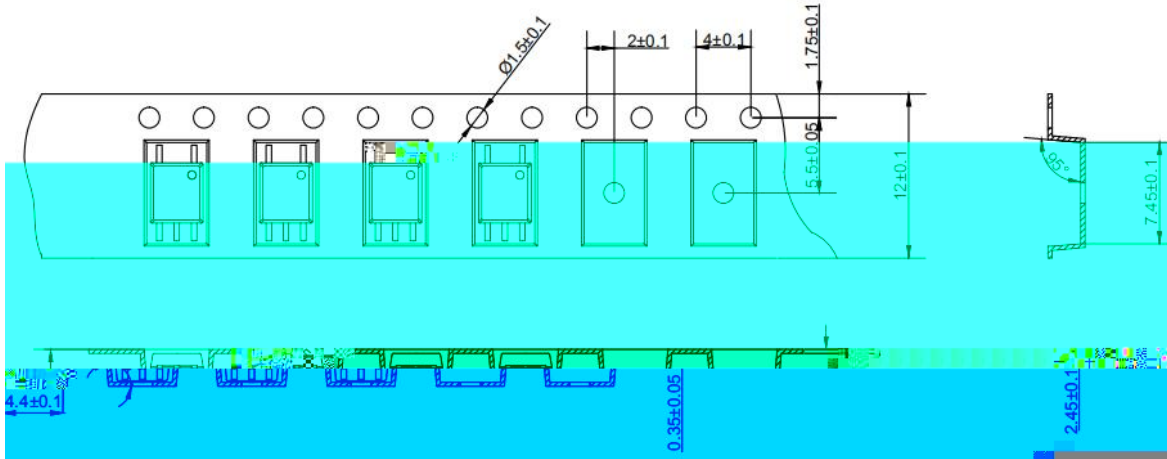

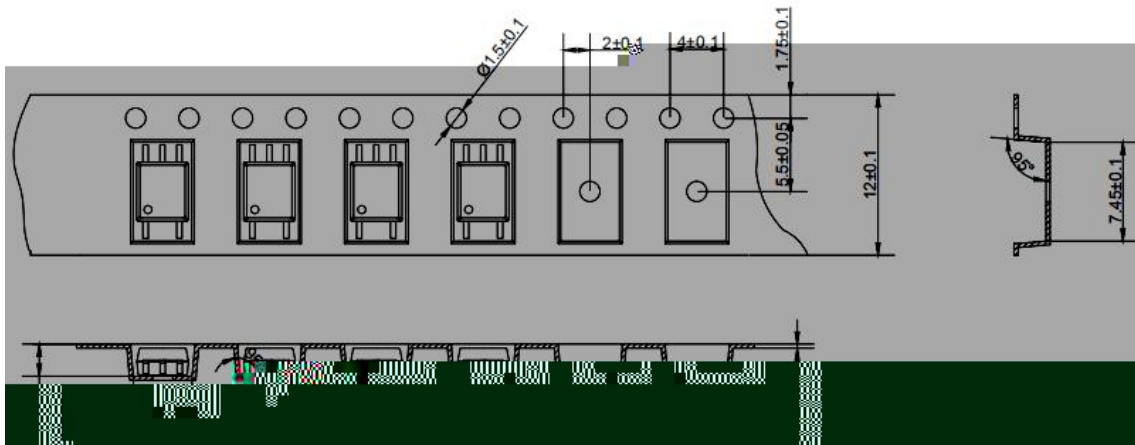

()



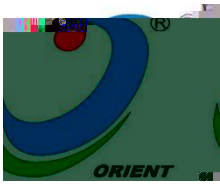

		()
		()
		()
		()
		()

()	



 **ORIENT**
ShenZhen Orient
Components Co.,LTD

Material Code : 120PCXXXXXX

|||||
P/N: OR-XXXXXX

|||||

Material Code: XXXXX XXXXX XXXXX

D/C: XXXX

Qty: XXXX PCS

内箱码



外箱码

“XXXXXXXXXXXXXXXXXX”

Made in China

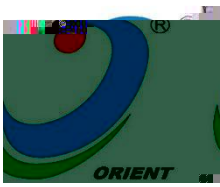
:



	存储				仪	
	低 存储				低 仪	
					冷 冲 击	
	 冲击				冷 冲 击	
	作				仪、 化	
	人体				仪	
	可					
	寿命				仪	
	压力				压力	

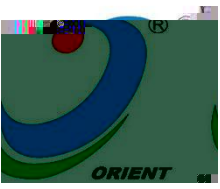

()

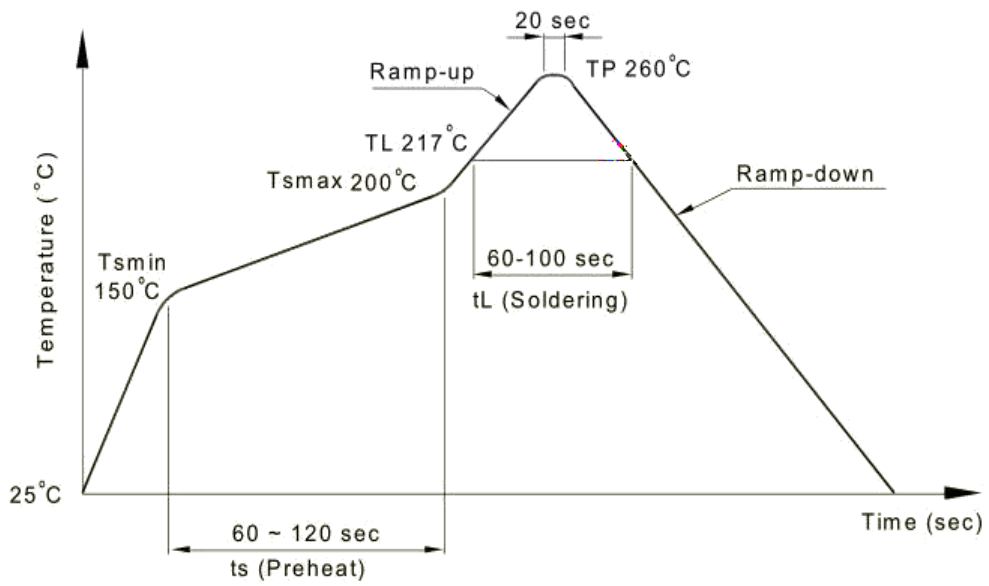

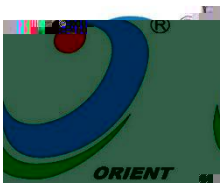

()

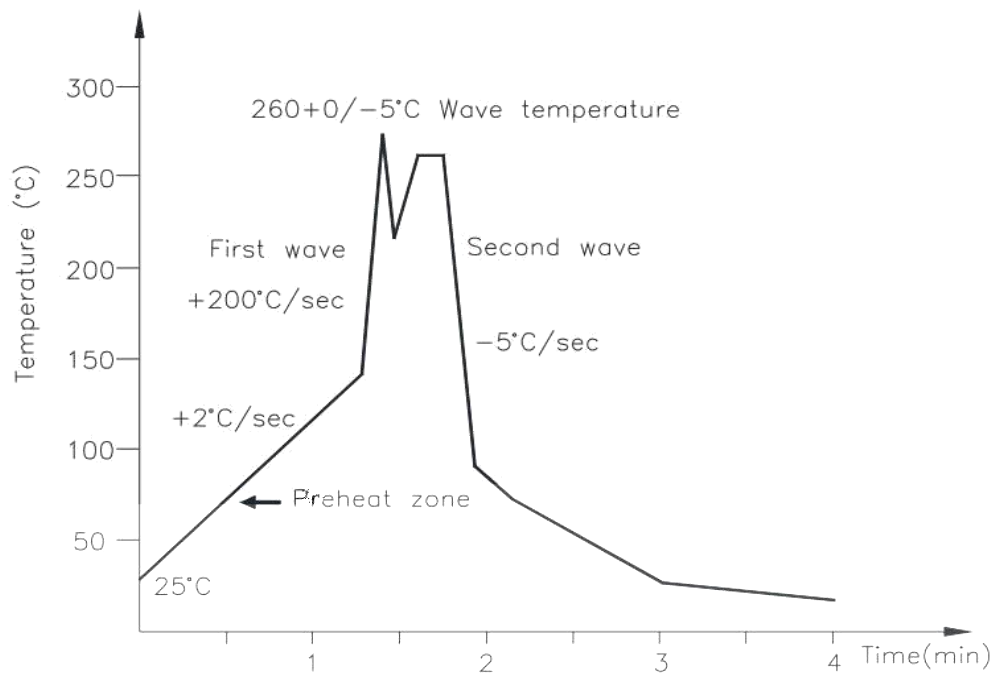

()

--	--

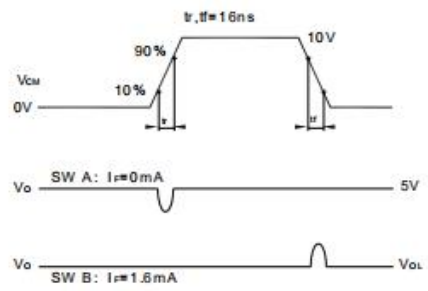
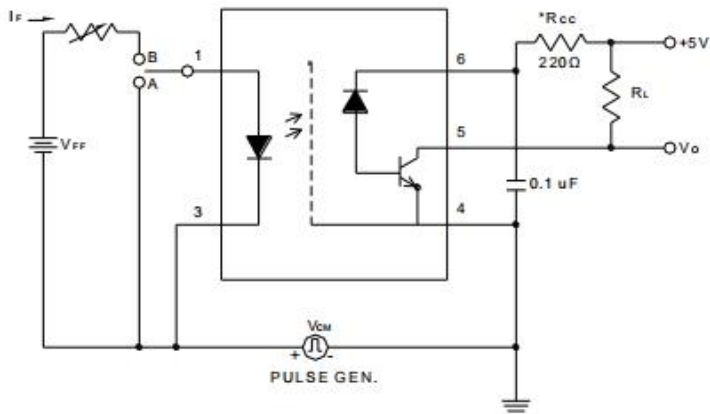
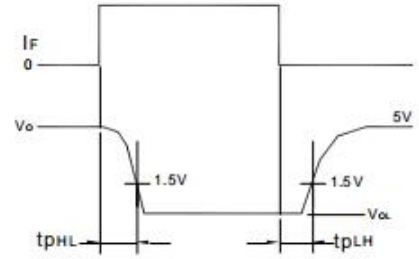
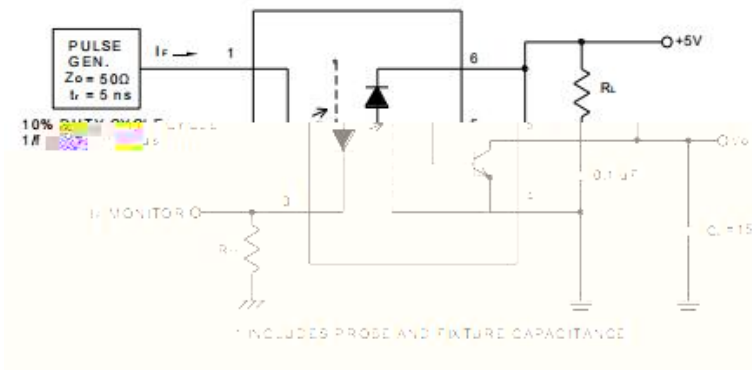
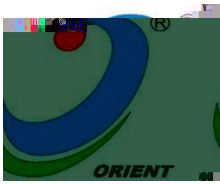

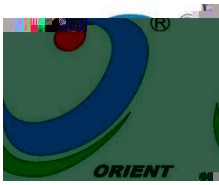

Figure 3: DC and pulsed transfer characteristics

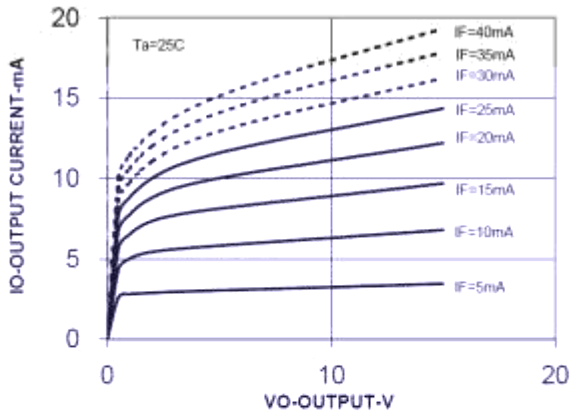

Figure 4: Input current vs. forward voltage

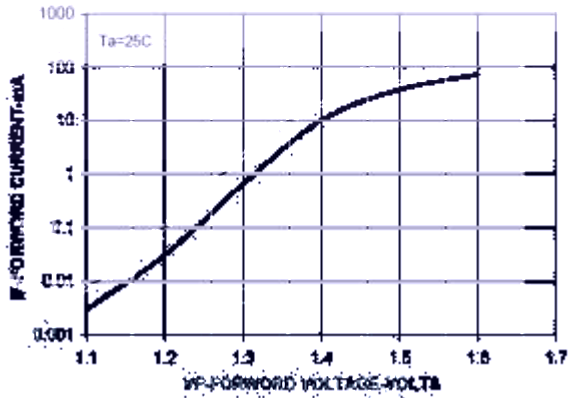

Figure 5: Logic high output current vs. temperature

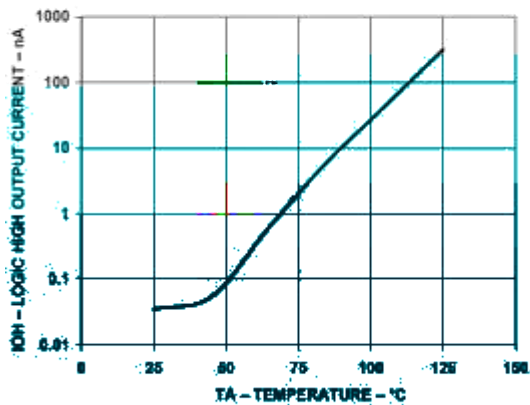

Figure 6: Current transfer ratio vs. input current

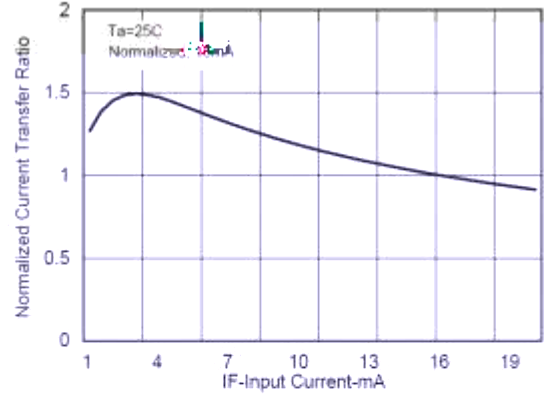

Figure 7. NORMALIZED CURRENT TRANSFER RATIO VS. AMBIENT TEMPERATURE

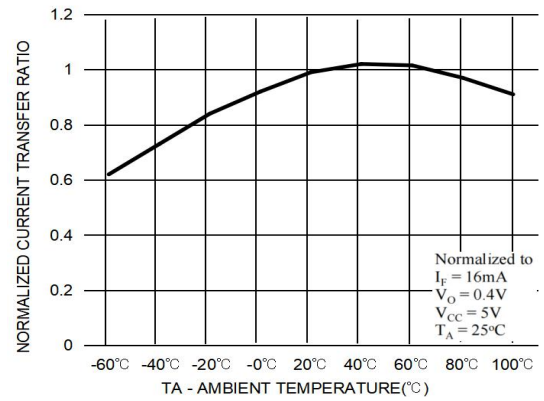
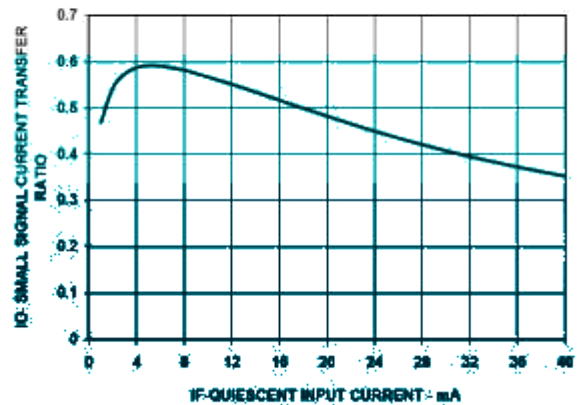

Figure 8: Small-signal current transfer ratio vs. quiescent current



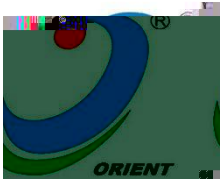

Figure 9: Propagation delay time vs. temperature

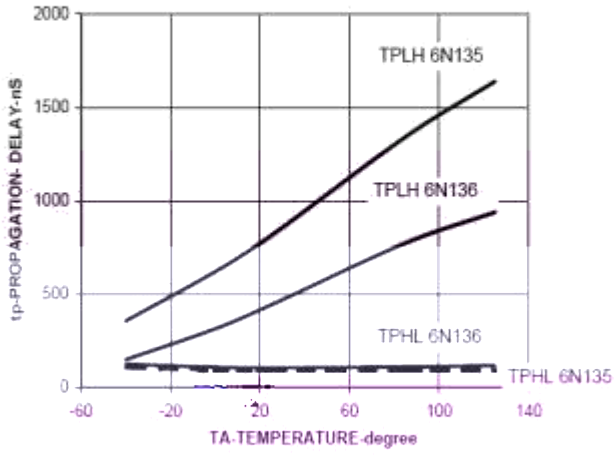

Figure 10: Propagation delay time vs. load resistance

